



10Gb/s 850nm Multimode SFP+ Transceiver XGSFP-M-LC-01

Features

- 10Gb/s serial optical interface compliant to 802.3ae 10GBASE-SR
- Electrical interface compliant to SFF-8431 specifications for enhanced 8.5 and 10 Gigabit small form factor pluggable module "SFP+"
- 850nm VCSEL transmitter, PIN photo-detector, Chip On Board
- 2-wire interface for management specifications compliant with SFF 8472 digital diagnostic monitoring interface for optical transceivers
- Operating case temperature: 0 to 70°C
- All-metal housing for superior EMI performance
- Low power consumption
- Advanced firmware allow customer system encryption information to be stored in transceiver
- Cost effective SFP+ solution, enables higher port densities and greater bandwidth
- RoHS compliant



Applications

- High-speed storage area networks
- Computer cluster cross-connect
- Custom high-speed data pipes
- Inter Rack Connection

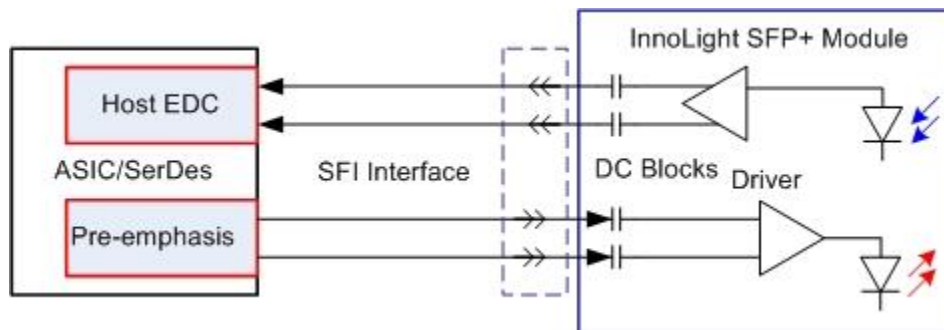

Figure1: Application in System



1. GENERAL DESCRIPTION

This 850 nm VCSEL 10Gigabit SFP+ transceiver is designed to transmit and receive optical data over 50/125 μm or 62.5/125 μm multimode optical fiber (Table 1).

Fiber type	850nm OFL Bandwidth	Supported Distances (meters)
62.5 μm MMF	160MHz-km	2 to 26
	OM1 200 MHz-km	2 to 33
50 μm MMF	400 MHz-km	2 to 66
	OM2 500 MHz-km	2 to 82
	OM3 2000 MHz-km	2 to 300

Table 1: SFP+ SR Operating Range for each Optical Fiber Type

The SFP+ SR module electrical interface is compliant to SFI electrical specifications. The transmitter input and receiver output impedance is 100 Ohms differential. Data lines are internally AC coupled. The module provides differential termination and reduce differential to common mode conversion for quality signal termination and low EMI. SFI typically operates over 200 mm of improved FR4 material or up to about 150mm of standard FR4 with one connector.

The transmitter converts 10Gbit/s serial PECL or CML electrical data into serial optical data compliant with the 10GBASE-SR standard. An open collector compatible Transmit Disable (Tx_Dis) is provided. Logic "1" or no connection on this pin will disable the laser from transmitting. Logic "0" on this pin provides normal operation. An open collector compatible Transmit Fault (Tx_Fault) is provided. TX_Fault is module output contact that when high, indicates that the module transmitter has detected a fault condition related to laser operation or safety. The TX_Fault output contact is an open drain/collector and shall be pulled up to the Vcc_Host in the host with a resistor in the range 4.7-10 k Ω . TX_Disable is a module input contact. When TX_Disable is asserted high or left open, the SFP+ module transmitter output shall be turned off. This contact shall be pulled up to VccT with a 4.7 k Ω to 10 k Ω resistor

The receiver converts 10Gbit/s serial optical data into serial PECL/CML electrical data. An open collector compatible Loss of Signal is provided. Rx_LOS when high indicates an optical signal level below that specified in the relevant standard. The Rx_LOS contact is an open drain/collector output and shall be pulled up to Vcc_Host in the



host with a resistor in the range 4.7-10 kΩ, or with an active termination. Power supply filtering is recommended for both the transmitter and receiver. The Rx_LOS signal is intended as a preliminary indication to the system in which the SFP+ is installed that the received signal strength is below the specified range. Such an indication typically points to non-installed cables, broken cables, or a disabled, failing or a powered off transmitter at the far end of the cable.

2. TRANSCEIVER BLOCK DIAGRAM

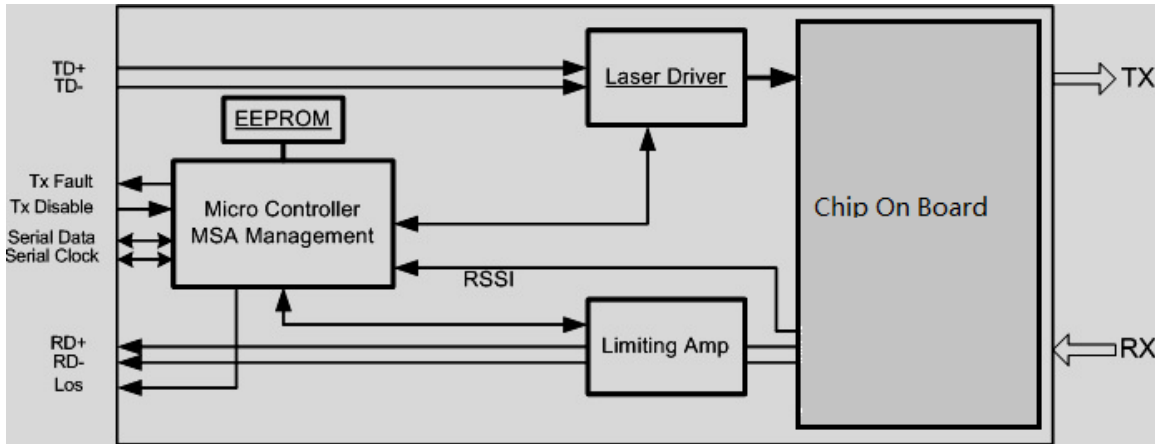



3. PROPOSED APPLICATION SCHEMATICS

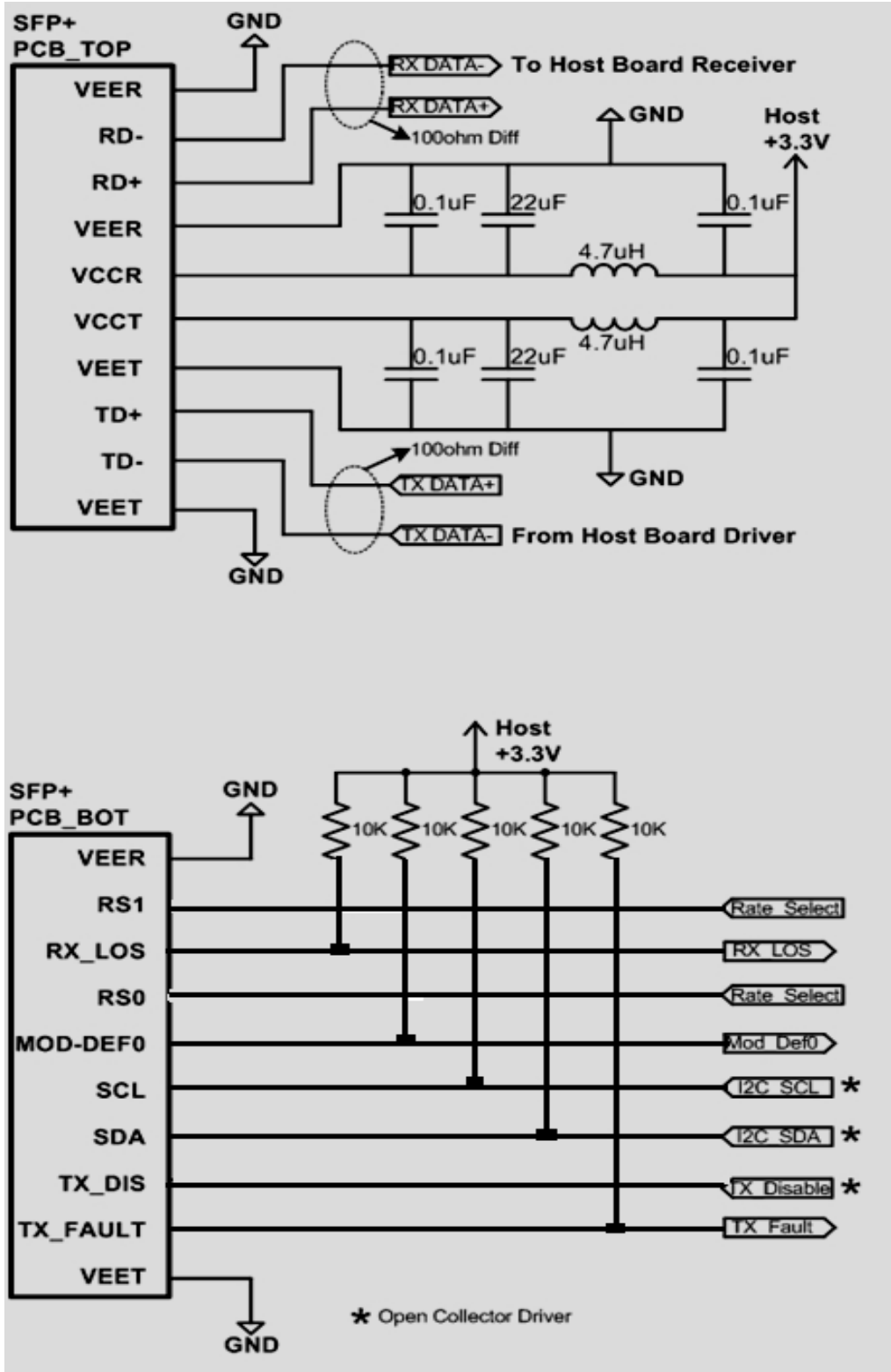



4. PIN DEFINITION

The SFP+ modules are hot-pluggable. Hot pluggable refers to plugging in or unplugging a module while the host board is powered. The SFP+ host connector is a 0.8 mm pitch 20 position right angle improved connector specified by SFF-8083, or stacked connector with equivalent electrical performance. Host PCB contact assignment is shown in Figure 4 and contact definitions are given in the PIN description table. SFP+ module contacts mates with the host in the order of ground, power, followed by signal as illustrated by Figure 5 and the contact sequence order listed in the PIN description table.

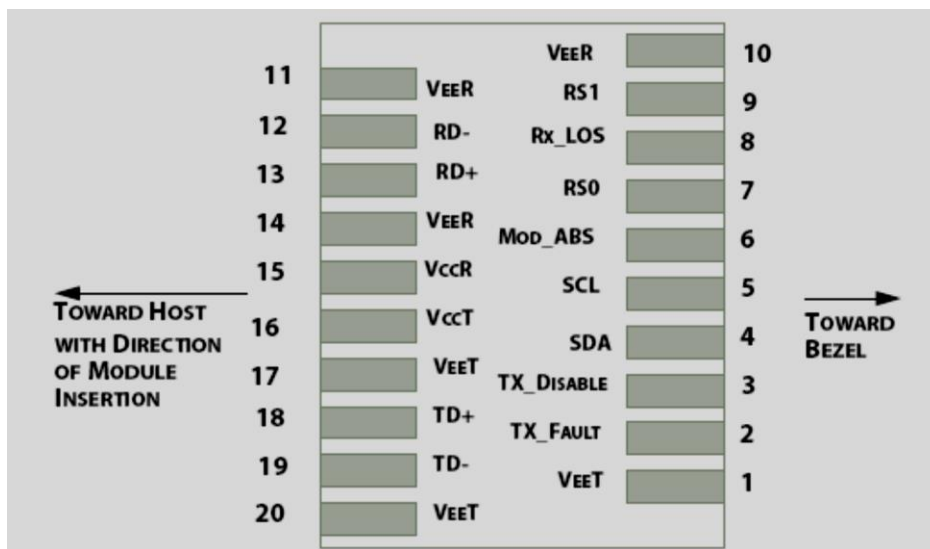

Figure 4: Module Interface to Host

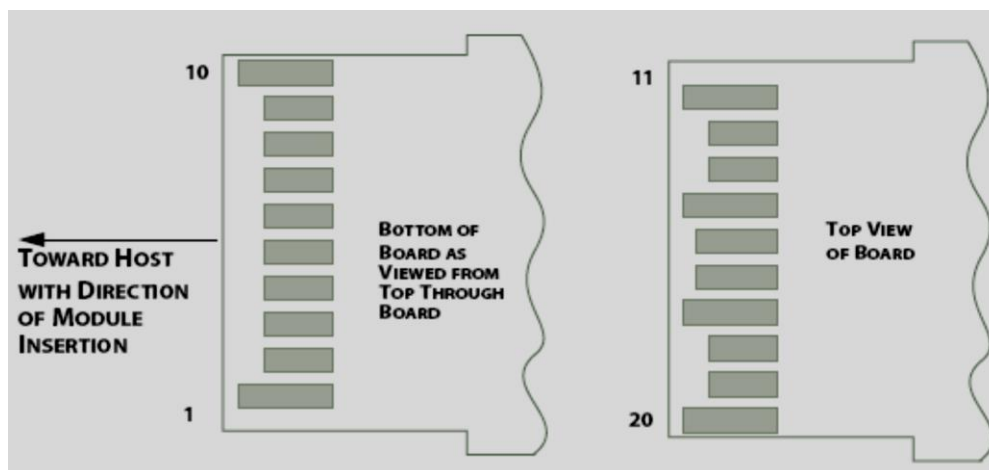

Figure 5: Module Contact Assignment

PIN description



PIN	Logic	Symbol	Name / Description	Note
1		VeeT	Module Transmitter Ground	1
2	LVTTTL-O	TX_Fault	Module Transmitter Fault	
3	LVTTTL-I	TX_Dis	Transmitter Disable; Turns off transmitter laser output	
4	LVTTTL-I/O	SDA	2-Wire Serial Interface Data Line	2
5	LVTTTL-I	SCL	2-Wire Serial Interface Clock	2
6		MOD_DEF0	Module Definition, Grounded in the module	
7	LVTTTL-I	RS0	Receiver Rate Select	
8	LVTTTL-O	RX_LOS	Receiver Loss of Signal Indication Active LOW	
9	LVTTTL-I	RS1	Transmitter Rate Select (not used)	
10		VeeR	Module Receiver Ground	1
11		VeeR	Module Receiver Ground	1
12	CML-O	RD-	Receiver Inverted Data Output	
13	CML-O	RD+	Receiver Data Output	
14		VeeR	Module Receiver Ground	1
15		VccR	Module Receiver 3.3 V Supply	
16		VccT	Module Receiver 3.3 V Supply	
17		VeeT	Module Transmitter Ground	1
18	CML-I	TD+	Transmitter Non-Inverted Data Input	
19	CML-I	TD-	Transmitter Inverted Data Input	
20		VeeT	Module Transmitter Ground	1

Note:

1. Module ground pins GND are isolated from the module case.
2. Shall be pulled up with 4.7K-10Kohms to a voltage between 3.15V and 3.45V on the host board.



5. ABSOLUTE MAXIMUM RATING

These values represent the damage threshold of the module. Stress in excess of any of the individual Absolute Maximum Ratings can cause immediate catastrophic damage to the module even if all other parameters are within Recommended Operating Conditions.

Parameters	Symbol	Min.	Max.	Unit
Power Supply Voltage	VCC	0	3.6	V
Storage Temperature	Tc	-40	85	°C
Operating Case Temperature	Tc	0	70	°C
Relative Humidity	RH	5	95	%
RX Input Average Power	Pmax	-	1.5	dBm

6. RECOMMENDED OPERATING ENVIRONMENT

Recommended Operating Environment specifies parameters for which the electrical and optical characteristics hold unless otherwise noted.

Parameters	Symbol	Min.	Typical	Max	Unit
Power Supply Voltage	VCC	3.135	3.3	3.465	V
Power Supply Current	Icc			250	mA
Operating Case Temperature	TC	0	25	70	°C



7. OPTICAL CHARACTERISTICS

The following optical characteristics are defined over the Recommended Operating Environment unless otherwise specified.

Parameter	Symbol	Min.	Typical	Max	Unit	Notes
Transmitter						
Center Wavelength	λ_t	840	850	860	nm	
RMS spectral width	P_m	-	-	0.45	nm	1
Average Optical Power	P_{avg}	-5	-	-1	dBm	
Optical Power OMA	P_{oma}	-	-1.5		dBm	1
Laser Off Power	P_{off}	-	-	-30	dBm	
Extinction Ratio	ER	3.5	-	-	dB	
Transmitter Dispersion Penalty	TDP	-	-	3.9	dB	
Relative Intensity Noise	R_{in}	-	-	-128	dB/Hz	12dB reflection
Optical Return Loss Tolerance		-	-	12	dB	
Receiver						
Center Wavelength	λ_r	840	850	860	nm	
Receiver Sensitivity (OMA)	P_{sens}	-	-	-11.1	dBm	
Stressed Sensitivity (OMA)		-	-	-7.5	dBm	
LOS Assert	LOSA	-30	-	-	dBm	
LOS Deassert	LOSD	-	-	-12	dBm	
LOS Hysteresis	LOSH	0.5	-	-	dB	
Overload	P_{in}	-	-	-1	dBm	
Receiver Reflectance		-	-	-12	dB	

Note1: Per Tradeoff Table 52.8, IEEE 802.3ae 2005



8. DIGITAL DIAGNOSTIC FUNCTIONS

The following digital diagnostic characteristics are defined over the Recommended Operating Environment unless otherwise specified. It is compliant to SFF8472 Rev11 with internal calibration mode. For external calibration mode please contact our sales

Parameter	Symbol	Min.	Max	Unit	Notes
Temperature monitor absolute error	DMI_Temp	-3	3	degC	Over operating temp
Laser power monitor absolute error	DMI_TX	-3	3	dB	
RX power monitor absolute error	DMI_RX	-3	3	dB	-1dBm to -12dBm range
Supply voltage monitor absolute error	DMI_VCC	-0.08	0.08	V	Full operating range
Bias current monitor	DMI_Ibias	-10%	10%	mA	



9. ELECTRICAL CHARACTERISTICS

The following electrical characteristics are defined over the Recommended Operating Environment unless otherwise specified.

Parameter	Symbol	Min.	Typical	Max	Unit	Notes
Data Rate		-	10.3125	-	Gbps	
Power Consumption		-	600	800	mW	
Transmitter						
Single Ended Output Voltage Tolerance		-0.3	-	4	V	
C common mode voltage tolerance		15	-	-	mV	
Tx Input Diff Voltage	VI	180		700	mV	
Tx Fault	VoL	-0.3		0.4	V	At 0.7mA
Data Dependent Input Jitter	DDJ			0.1	UI	
Data Input Total Jitter	TJ			0.28	UI	
Receiver						
Single Ended Output Voltage Tolerance		-0.3	-	4	V	
Rx Output Diff Voltage	Vo	300		850	mV	
Rx Output Rise and Fall Time	Tr/Tf	30			ps	20% to 80%
Total Jitter	TJ			0.7	UI	
Deterministic Jitter	DJ			0.42	UI	



10. CONTROL AND STATUS I/O TIMING CHARACTERISTICS

Timing characteristics of control and status I/O are included in Table 8, which is also defined in SFF-8431.

Parameter	Symbol	Min	Max	Unit	Condition
TX_Disable assert time	t_off		10	Us	Timing from rising edge of TX_Disable to when the optical output falls below 10% of nominal
TX_Disable negate time	t_on		1	ms	Timing from falling edge of TX_Disable to when the modulated optical output rises above 90% of nominal
Time to initialize Including reset of TX_Fault	t_init		300	ms	From power on or negation of TX Fault using TX Disable
TX_fault assert time	TX_fault		100	us	From occurrence of fault to assertion of TX_fault
TX Disable to reset	t_reset	10		us	Time TX_Disable must be held high to reset TX_fault
Los assert time	t_loss_on		100	us	Time from LOS state to Rx_Los assert
Los Deassert Time	t_loss_off		100	us	Time from non_LOS state to Rx_Los deassert
Rate-Select Change Time	t_ratesel		10	us	Time from rising or falling edge of Rate Select input until receiver bandwidth is in conformance with appropriate specification
Serial ID Clock Rate	f_serial_clock		100	kHz	



11. MECHANICAL

Comply with SFF-8432 rev. 5.0, the improved Pluggable form factor specification.

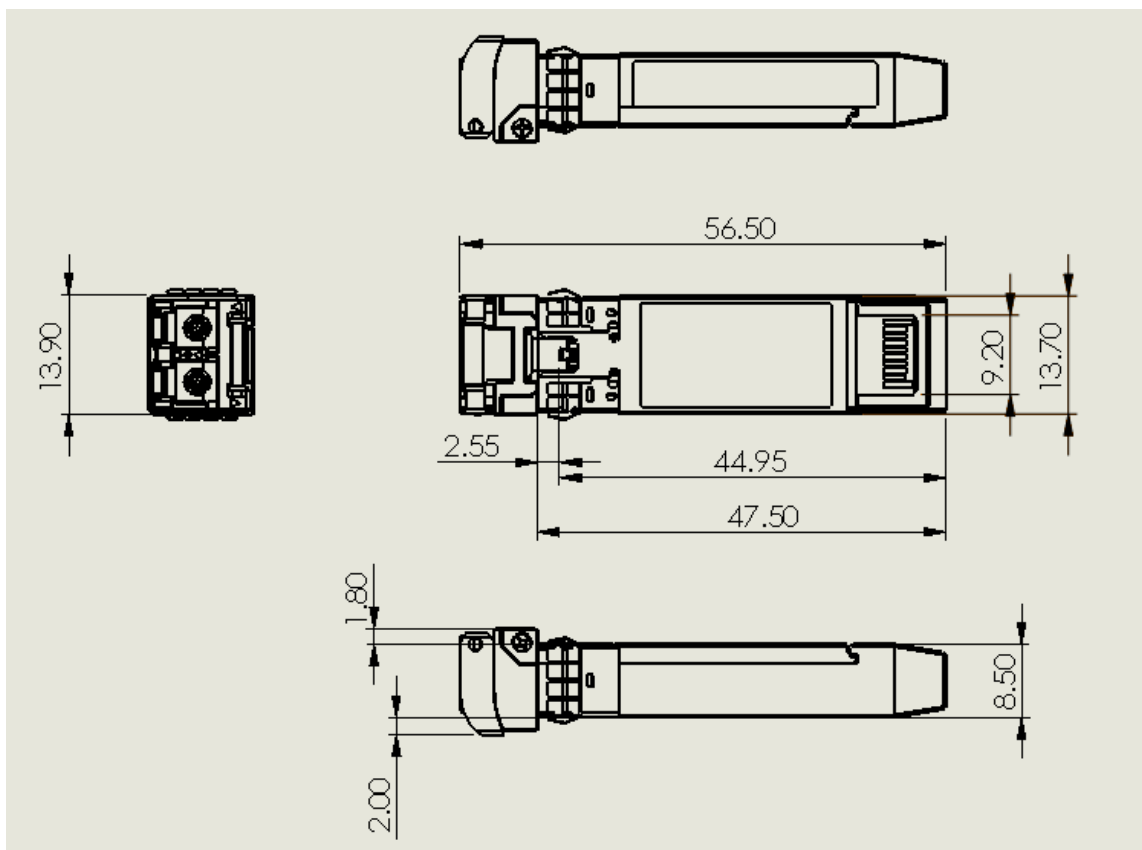

12. ESD

This transceiver is specified as ESD threshold 1kV for SFI pins and 2kv for all others electrical input pins, tested per MIL-STD-883, Method 3015.4 /JESD22-A114-A (HBM). However, normal ESD precautions are still required during the handling of this module. This transceiver is shipped in ESD protective packaging. It should be removed from the packaging and handled only in an ESD protected environment.

13. LASER SAFTY

This is a Class 1 Laser Product according to IEC 60825-1:2007. This product complies with 21 CFR 1040.10 and 1040.11 except for deviations pursuant to Laser Notice No. 50, dated (June 24, 2007)